

Water-Aerosol Interactions in Mexico City: Inferences about Aerosol Chemical Composition and Ageing

S.Lance^{1,2}, L.T.Padro¹, A.Nenes¹, J.Smith²,
C.Hennigan¹, R.Weber¹, X.Y.Yu³, T.Onasch⁴

¹Georgia Institute of Technology, ²National Center for Atmospheric Research, ³Pacific Northwest National Laboratory, ⁴Aerodyne Research Inc.

Acknowledgments:
NOAA, NCAR ASP, NSF-ATM, NSF-CAREER

Organics & CCN: The Challenges

- Representing the cumulative effect of organics on cloud formation realistically and simply.
(few lines of FORTRAN code in a global model)
- Use in-situ measurements to constrain state-of-the-art droplet parameterizations in global climate models.
- Desired information:
 - Chemical heterogeneity (mixing state) of aerosol
 - Average molar properties (molar volume, solubility)
 - Droplet growth kinetics
 - Surface tension depression

Measuring CCN: a key source of data

Goal: Generate supersaturation, expose CCN to it and count how many droplets form.

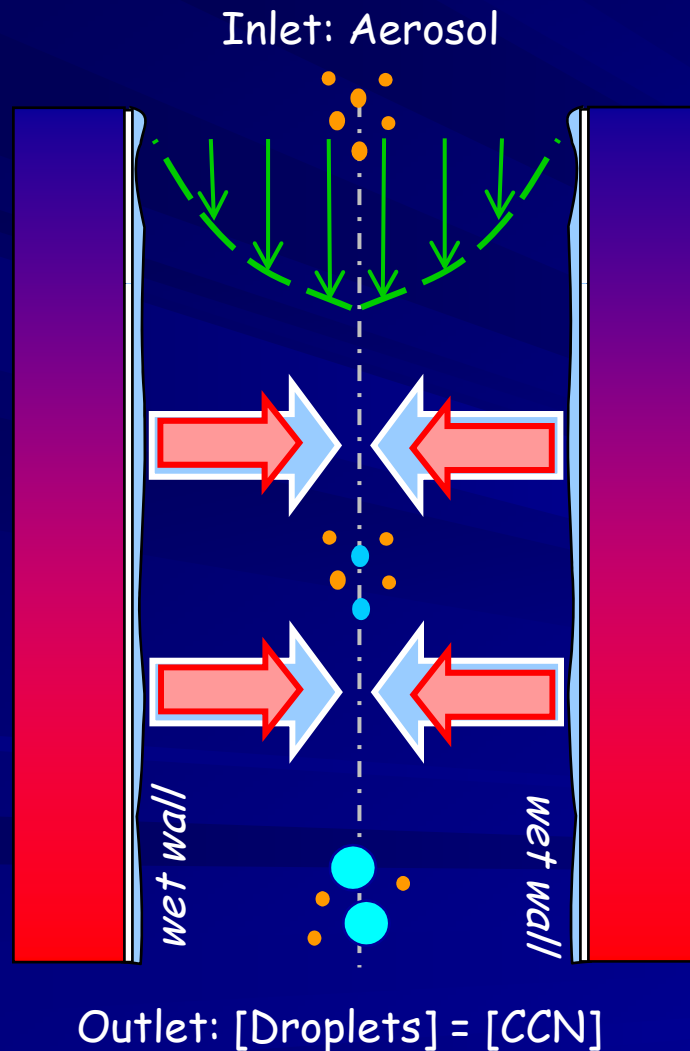

Our Method: Take a metallic cylinder, wet its walls. Cool one end, heat the other, and flow air through it.

- Wall saturated with H_2O . Linear temperature gradient.
- H_2O mass diffuses more quickly than heat and arrives at centerline first.
- The flow is supersaturated with water vapor at the centerline.
- Flowing aerosol would activate some into droplets.

Obtaining organic properties: General Approach

Collect Particles
(ambient or
filter sample)



Measure their CCN
properties as a function
of size and
supersaturation



Extract in Water



Measure surfactant
characteristics
(or other relevant props)



Measure inorg. composition
and total carbon



Use theory to infer the
properties we are
interested in.

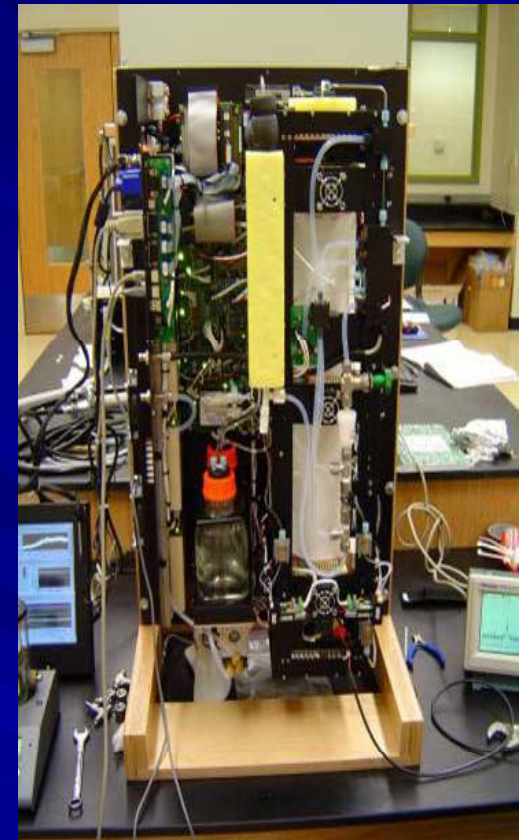

CAM-100
Pendant Drop
Tensiometer
for surface tension
measurements

DMT Streamwise Gradient
CCN Chamber for droplet
formation potential and
growth kinetics.

Size-resolved CCN: A rich source of information

Put a DMA upstream and measure CCN activity

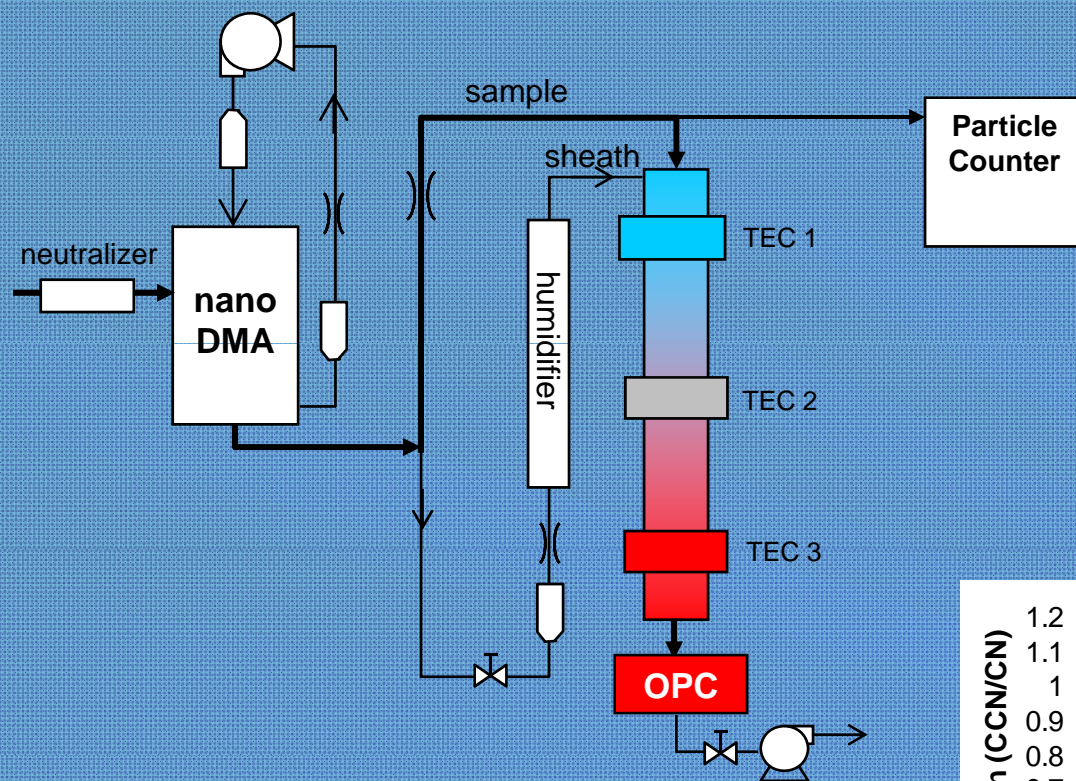

$$\text{Activated Fraction} = \frac{\text{CCN}}{\text{CN}}$$

Results: "activation curves"

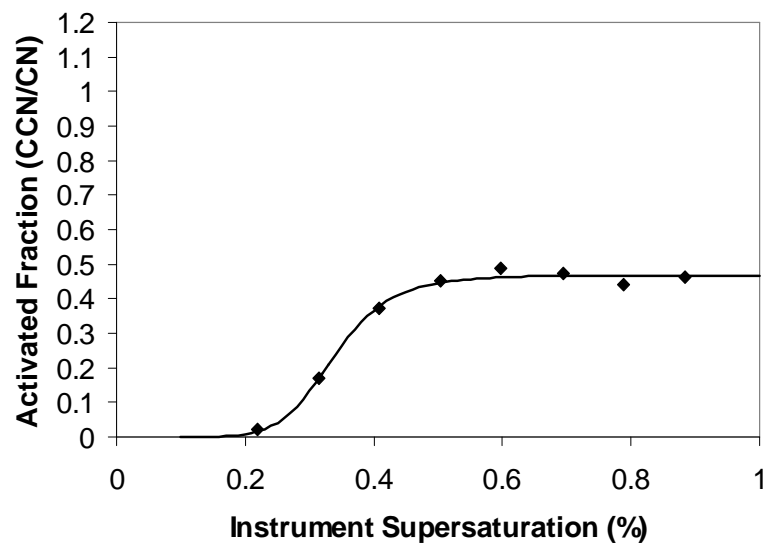

Organics & CCN: The Challenges

■ Desired information:

- **Chemical heterogeneity (mixing state) of aerosol**
- Average molar properties (molar volume, solubility)
- Droplet growth kinetics
- Surface tension depression

What the Activation Curves tell us

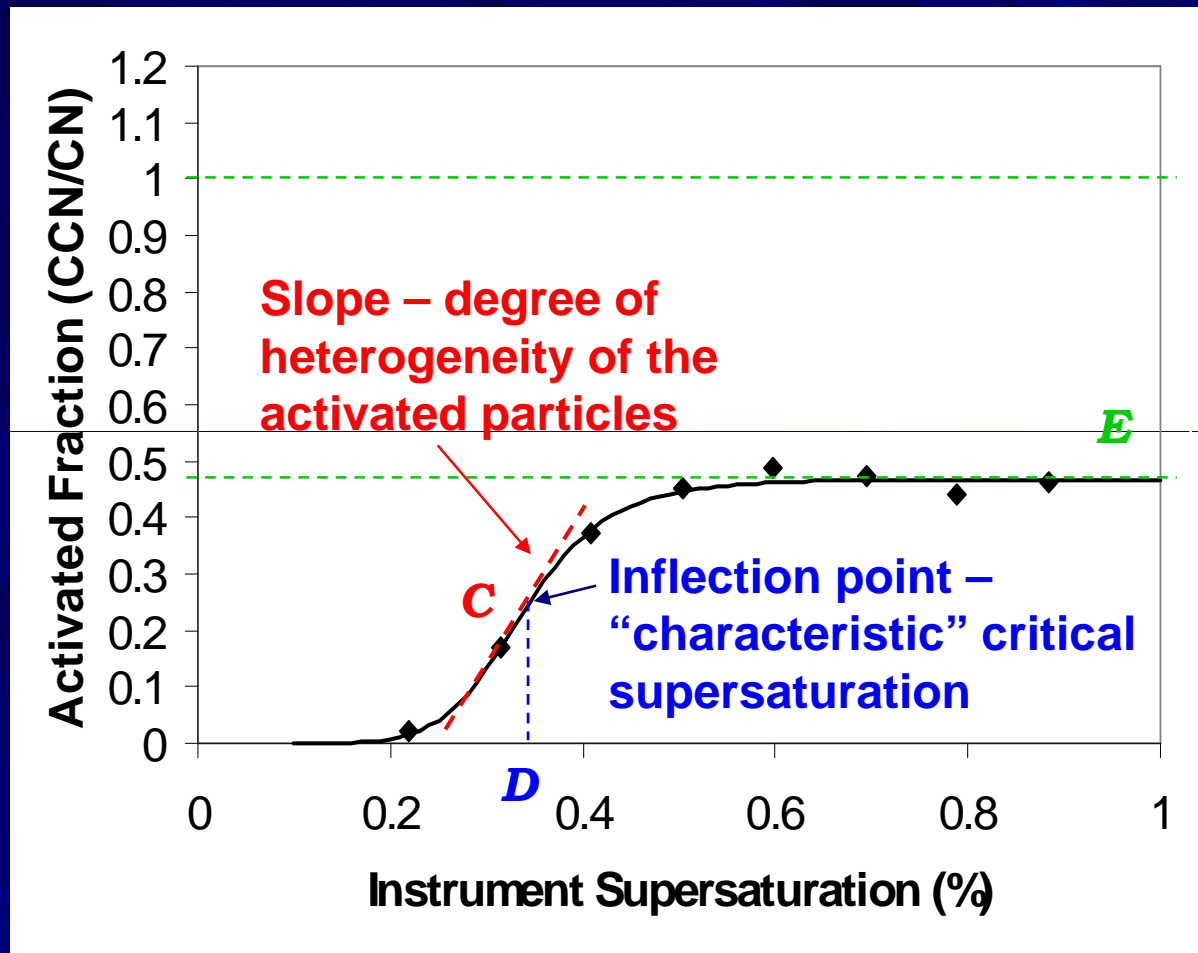

Fit the data
to a sigmoid

$$\frac{CCN}{CN} = \left[\frac{E}{1 + (S/D)^C} \right]$$

E : hygroscopic
fraction

What the Activation Curves tell us

Show data for D_p is constant, the sigmoid describes the distribution of critical supersaturations for that size.

This can be used to quantify the CCN **chemical heterogeneity**.

$$\left(\frac{CCN}{CN}\right)^* = \left(\frac{1}{1 + (S/D)^c}\right)$$

Normalized to remove the unactivated particles from the calculation

From Köhler Theory:

$$S_c = 100 \left[\exp\left(\frac{4A^3}{27B}\right)^{1/2} - 1 \right]$$

$$A = \frac{4M_w \sigma}{RT \rho_w}$$

$$B = \frac{M_w \rho_s V}{M_s \rho_w} D_p^3 \epsilon_s$$

We describe CCN activity as a mixture of soluble-insoluble compounds; the sigmoid then describes a **distribution** of soluble (salt) fraction for the CCN that activate.

**Result: We get aerosol mixing state
(distribution of composition) for each
particle size**

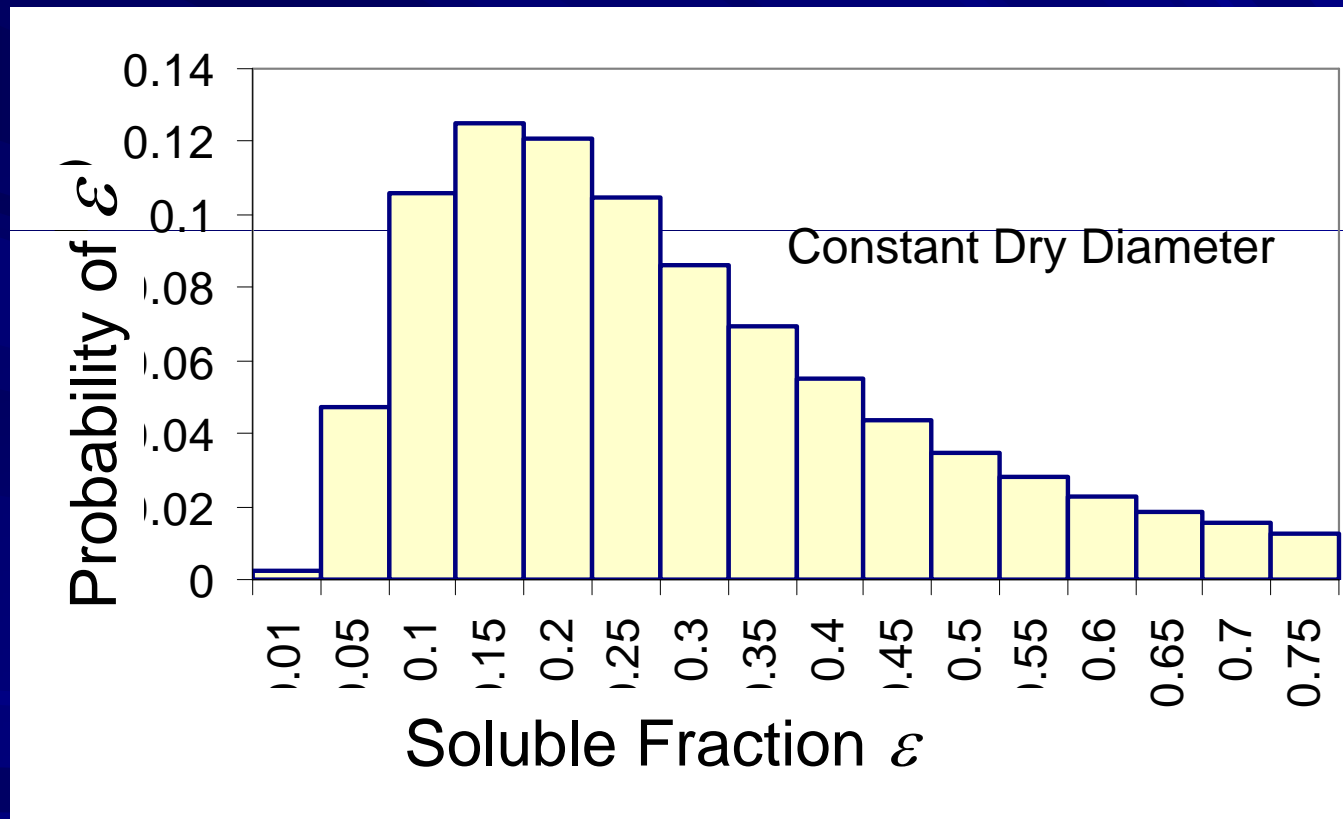

Lance et al., in review

This is wonderful information (if it works...)

Case Study: Measurements from the MILAGRO T1 ground site

Biomass burning, dust, diesel exhaust, sheep...



CCN Activation Curves

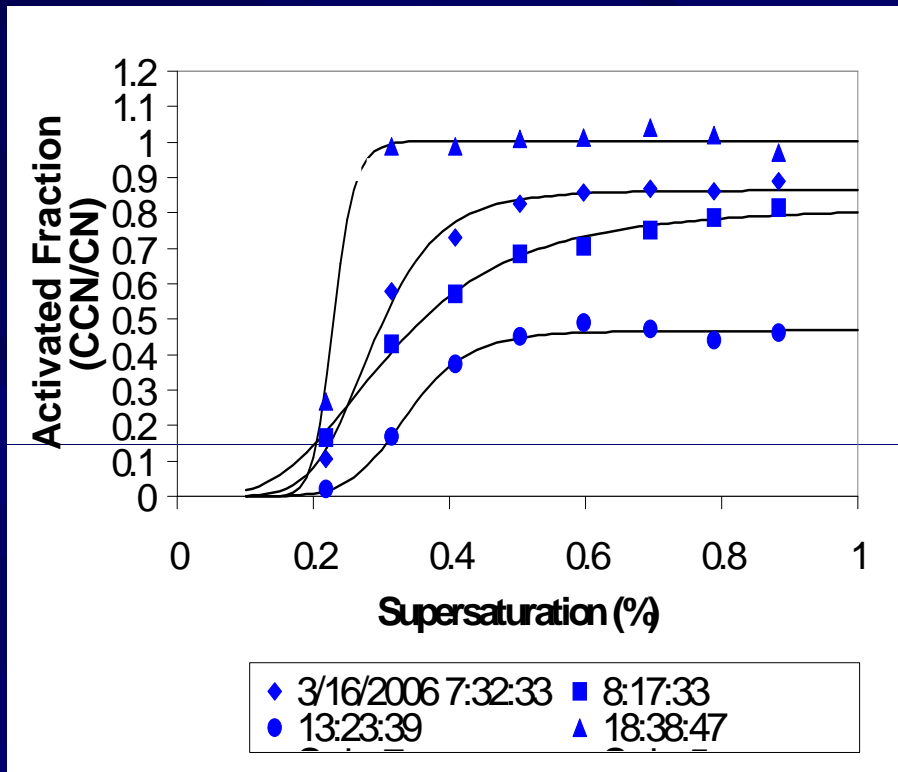

- Activation curves can vary significantly throughout the day
- Here, transition from very externally mixed at morning to well mixed by afternoon)

Activation curves change significantly with dry particle size

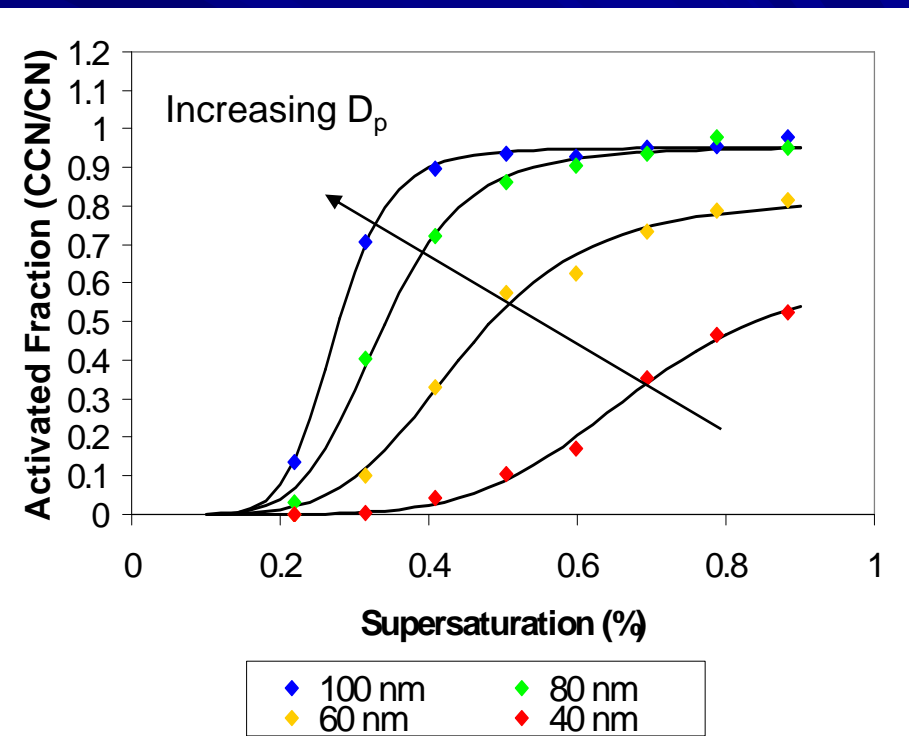

Derived vs. measured mass fractions

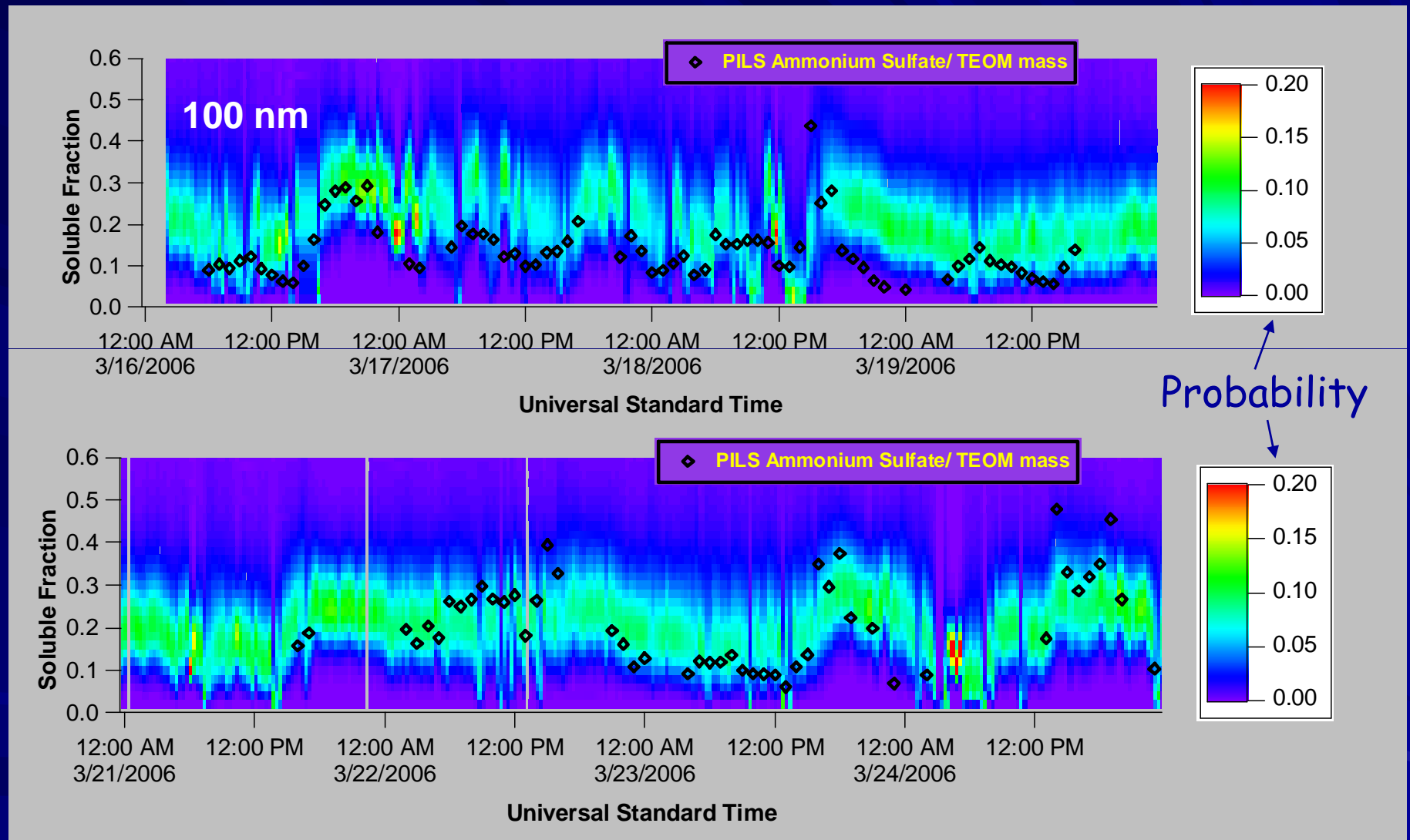

The idea works! We can now get PDF's of composition as a function of size.... Very powerful insight into chemical ageing and heterogeneity.

Organics & CCN: The Challenges

■ Desired information:

- Chemical heterogeneity (mixing state) of aerosol
- **Average molar properties (molar volume, solubility)**
- Droplet growth kinetics
- Surface tension depression

Inferring Molar Volume from CCN activity: Köhler Theory Analysis (KTA)

- Measure the saturation level (s_c) required for a particle of dry size d to form a droplet.
- Fit the measurements to a power law expression.
- Relate fitted coefficients to aerosol properties (e.g. molecular weight, solubility) by using Köhler theory:

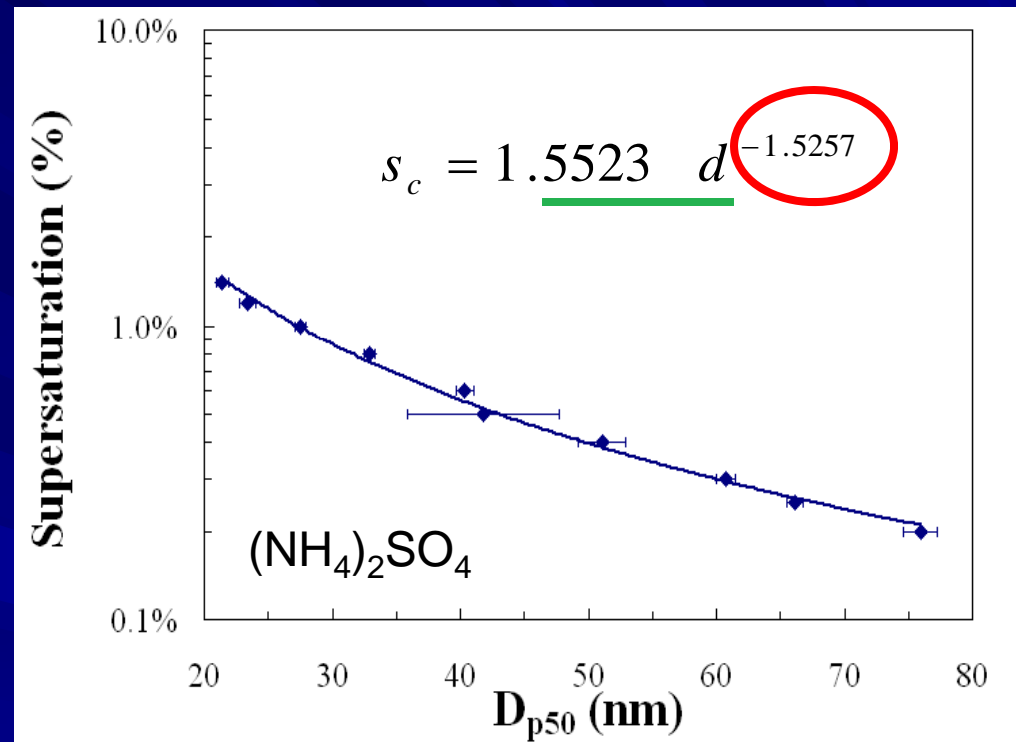

$$S_c = \left(\frac{256M_w\sigma}{27RT\rho_w} \right)^{1/2} \left[\sum_i \left(\frac{\rho_w}{M_w} \right) \left(\frac{M_i}{\rho_i} \right) \frac{1}{\varepsilon_i\nu_i} \right]^{1/2} d^{-3/2} = \omega d^{-3/2}$$

KTA: Getting Molar Volumes

$$\frac{M_{\text{organic}}}{\rho_{\text{organic}}} = \frac{\varepsilon_{\text{organic}} \nu_{\text{organic}}}{\frac{256}{27} \left(\frac{M_w}{\rho_w} \right)^2 \left(\frac{1}{RT} \right)^3 \sigma^3 \omega^{-2} - \sum_{i \neq \text{organic}} \frac{\rho_i}{M_i} \varepsilon_i \nu_i}$$

organics: ~ 1

Molar Volume
This is what you
need to know
about organics for
CCN activity

Constants

Measured surface
tension and cloud
chamber data

From IC/WSOC
measurement

$$\varepsilon_i = \frac{m_i / \rho_i}{\sum_i m_i / \rho_i}$$

Method shown to work well for laboratory-generated aerosol (Padró *et al.*, ACPD) and SOA generated from ozonolysis of biogenic VOC (Asa-Awuku *et al.*, in preparation).

CCN Measurements & KTA

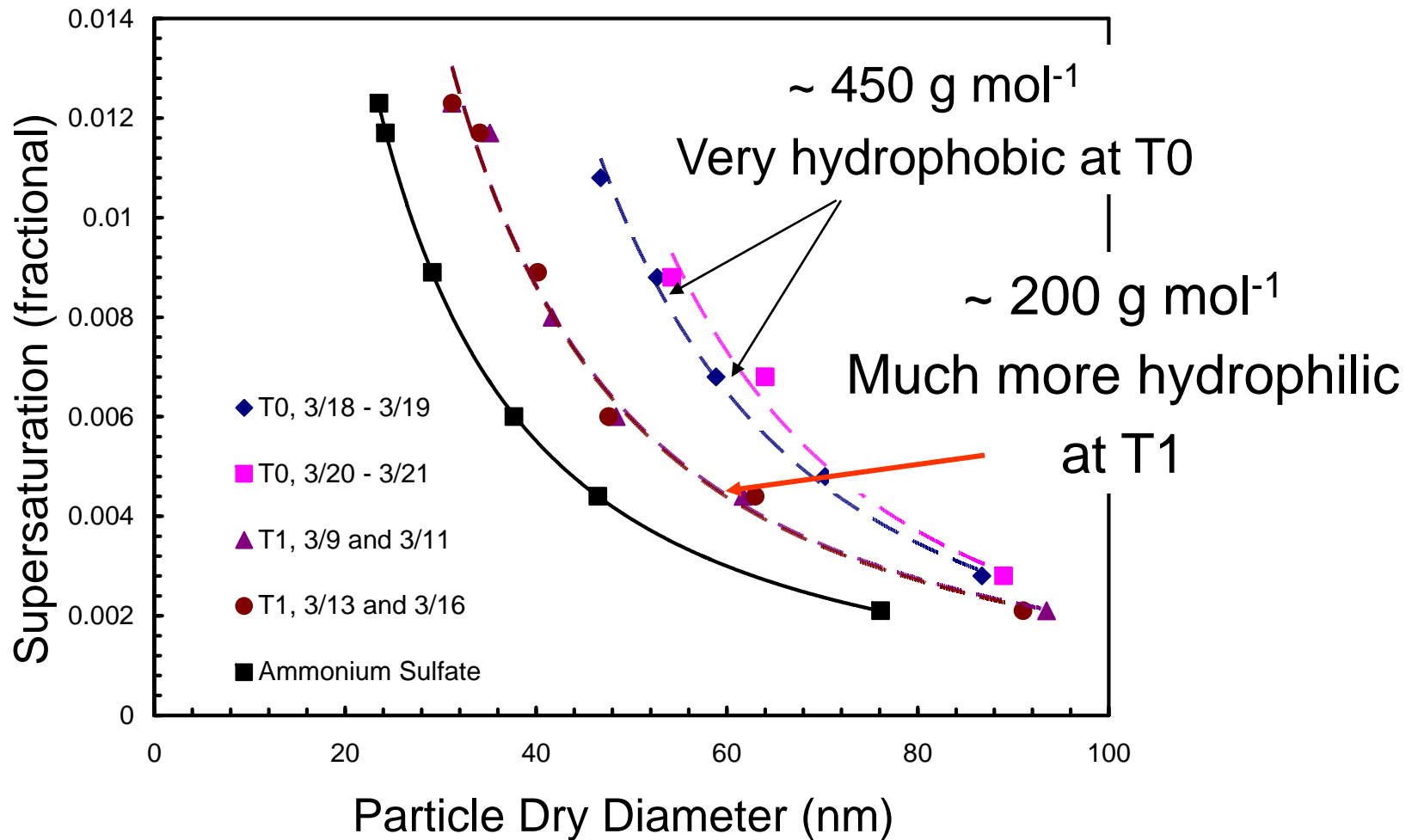

Key points:

- MW decreases by half over one day of transport. ← “parameterization-type”
- Direct consequence of chemical ageing processes. ← knowledge
- MW doesn't really change at each site (even if meteorology does!).

CCN Measurements: T0-T1 Contrasts

Site	Integration Period	Average Organic Molecular Weight (g mol ⁻¹)	Average Organic Molar Volume ^a (cm ³ mol ⁻¹)
T0	12 hr day	404.16 ± 290.70	288.68 ± 207.65
T1	24 hr	129.06 ± 61.90	89.10 ± 61.51
T1	12 hr night	145.40 ± 41.53	103.86 ± 29.67
T1	12 hr day	121.36 ± 16.28	86.69 ± 11.63

^a Assuming an average organic density of 1.4 g cm⁻³ (Turpin and Lim, 2001)

T0: organic properties is highly variable (~2× larger than T1)

T1: organic properties are quite **constant** regardless of day - this suggests T1 expresses **large scale** ("background") properties.

T1: Nighttime filters have larger MW than Daytime. Photochemical ageing increases the hygroscopicity

See Padró et al. poster for more information and details

Organics & CCN: The Challenges

■ Desired information:

- Chemical heterogeneity (mixing state) of aerosol
- Average molar properties (molar volume, solubility)
- **Droplet growth kinetics**
- Surface tension depression

Growth kinetics from CCN measurements

Size of activated droplets measured in the instrument.

The impact of composition on growth kinetics can be inferred:

- compare against the growth of $(\text{NH}_4)_2\text{SO}_4$ (thus giving a sense for the relative growth rates), and,
- use a model of the CCN instrument, to parameterize measured growth kinetics in terms of a water vapor uptake coefficient, α .

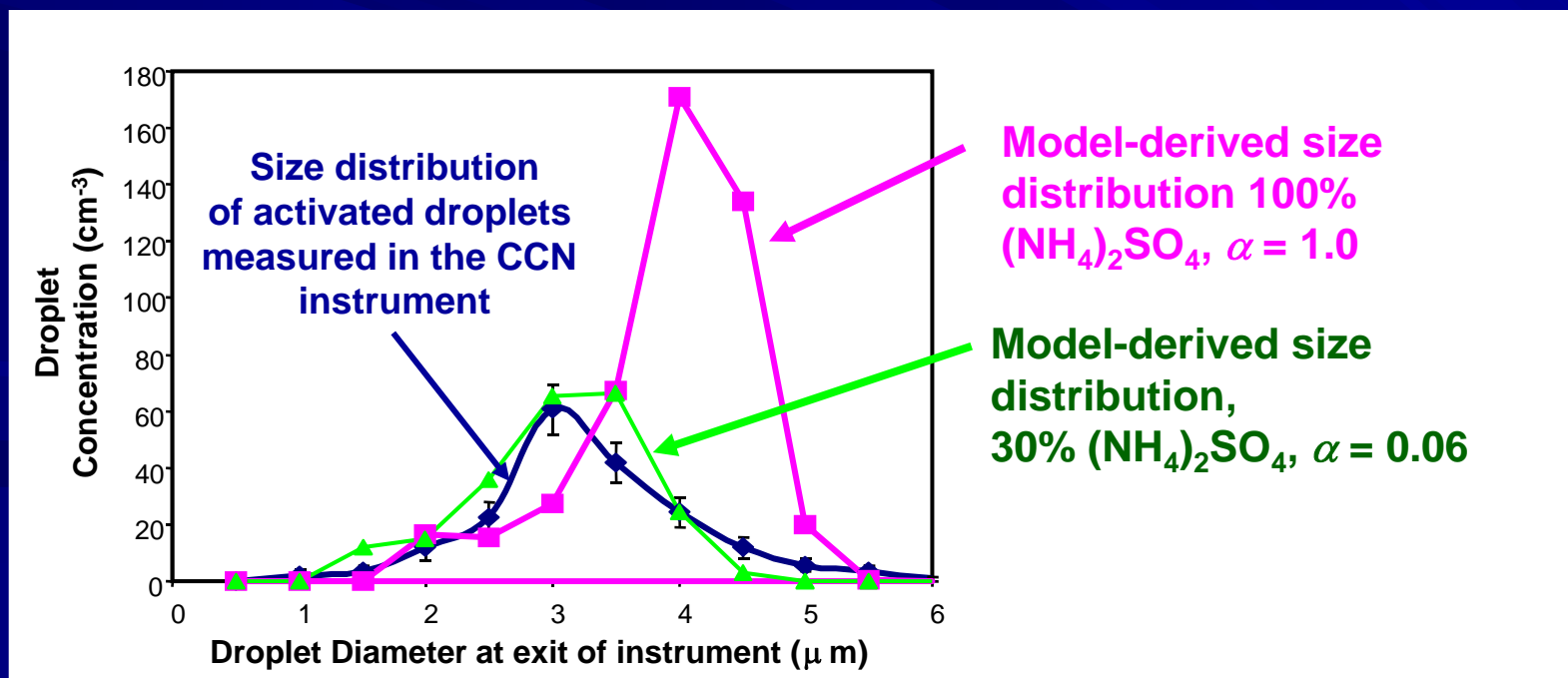

CCN growth kinetics at T1

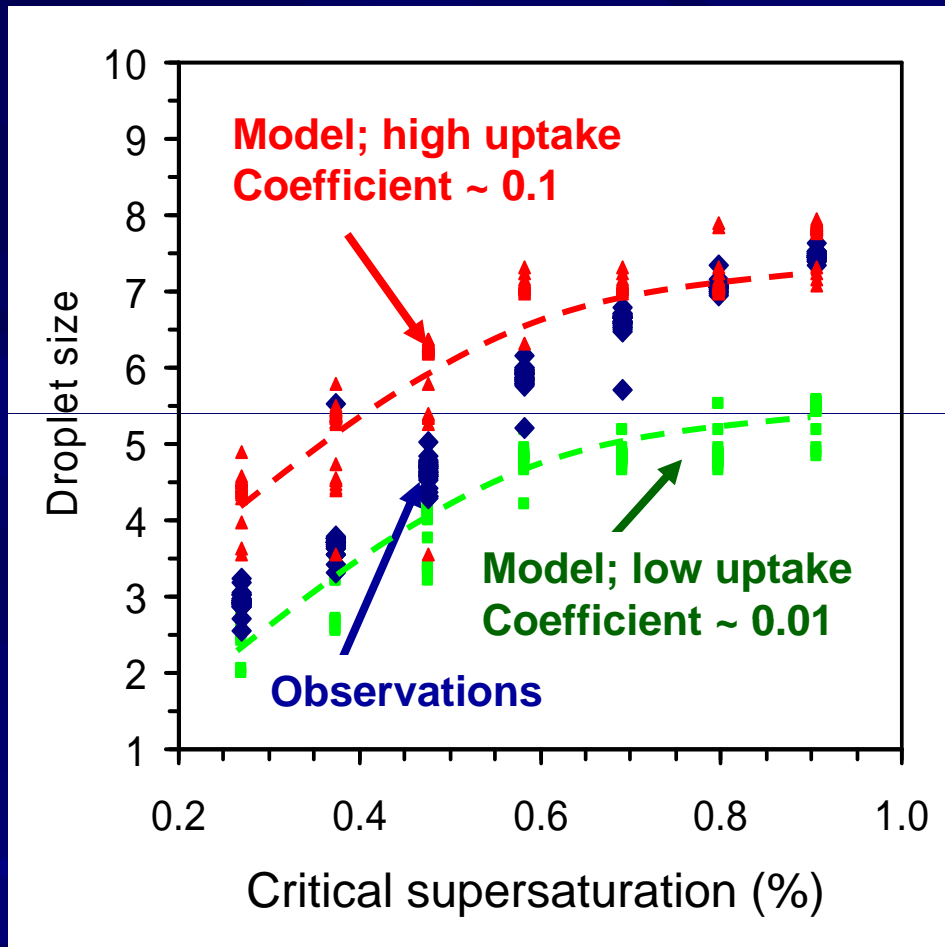

- Not all particles grow the same.
- There are many occasions where particles grow slowly.
- Large S_c particles grow fast, low S_c particles grow slowly. This is consistent with organic "films".
- We know strong surfactants are present (surface tension measurements show this).

GCM simulations suggest this range of α can have a HUGE impact on the indirect effect ($\sim 1W m^{-2}$) (Nenes et al, in preparation)

"Take home" points

- In the right way CCN measurements are very powerful:
 - Chemical heterogeneity (mixing state) of aerosol
 - Average organic properties (MW, solubility)
 - Droplet growth kinetics
 - Surface tension depression, C/OC (not shown)...

"Parameterization-type" information nuggets

- Average molecular weight of organics change twofold between fresh emissions (T0) and aged aerosol (T1).
- The organic molecular weights at T1 (120-140) do not vary much and represent a large-scale background value.
- Surfactants are important; their influence is \sim constant.
- The growth kinetics of the particles vary substantially, and is potentially very important for the indirect effect.